

## TV Wall Mount

Tilt





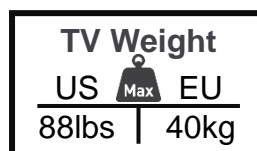

For more information: [barkanmounts.com](https://www.barkanmounts.com)

If you are satisfied with the product, please give us a 5 stars ☆☆☆☆☆ rating on the website you bought it from. If you are not satisfied please contact us at <https://www.barkanmounts.com/support> and we will solve the problem for you.

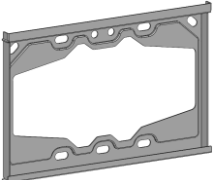
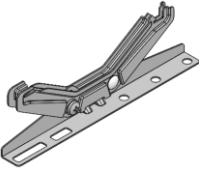
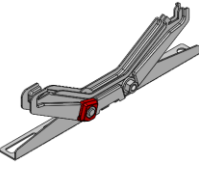

**Safety instructions and installation warnings (provided separately) must be read in full, prior to assembly.**

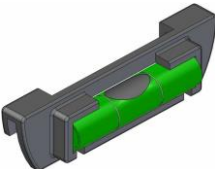
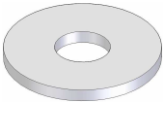
# Included Parts not to scale

<b>A</b> Wall Plate  x1	<b>B</b> TV Rail  x1	<b>C</b> TV Rail  x1
<b>Z4</b>  x4	<b>Z7</b>  x8	<b>Z8</b> Bubble level  x1
<b>W1</b>  x3	<b>W2</b>  x3	<b>W3</b>  x3

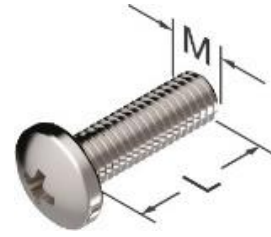

#	M	L mm	L inch	pcs
Z1	6	16	5/8	4
Z2	6	25	1	4
Z3	4	20	3/4	4
Z5	8	25	1	4
Z6	8	45	1 3/4	4

## Required Tools

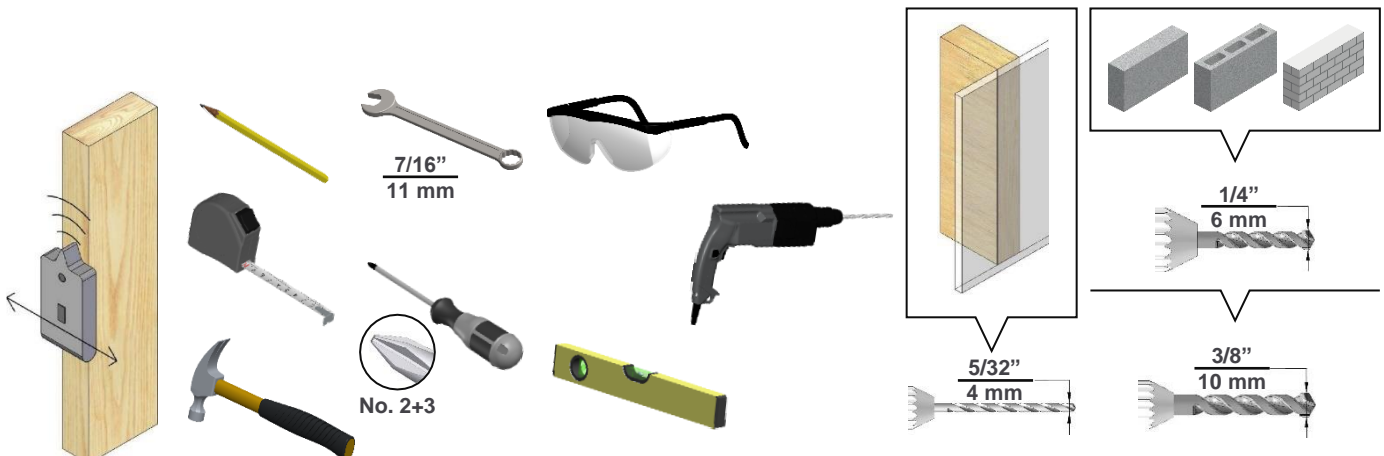

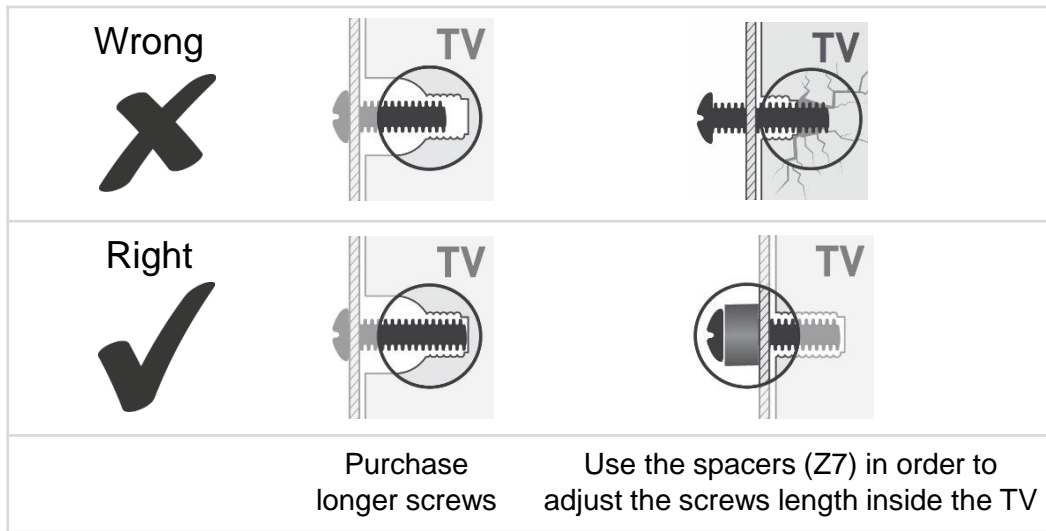

**1** Follow the steps according to your TV's cable connection type. (Is it parallel or perpendicular to the wall?)

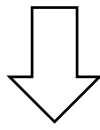
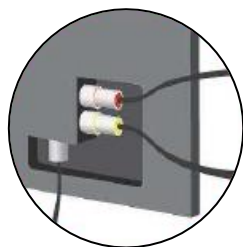

**1a**

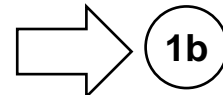
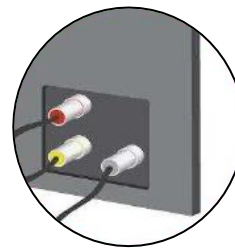

Page 4

**1a** Connect the TV rails (B and C) to the back of the TV at all 4 connection holes, while the plastic spacers (Z7) are on top of the vertical rails. Choose the bolt that fits the TV's mounting holes diameter.

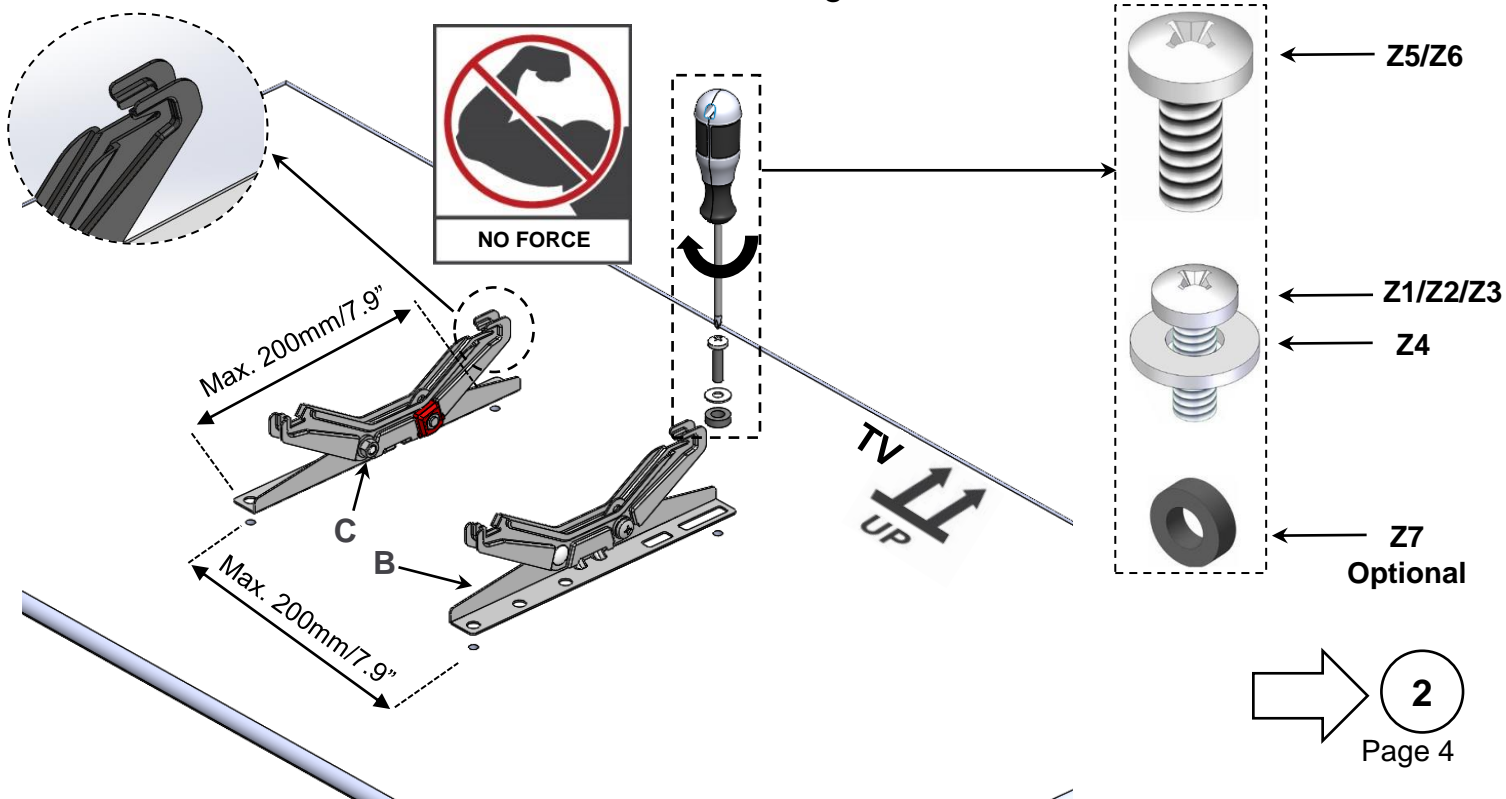

**2**  
Page 4

**1b** Connect the TV rails (B and C) to the back of the TV at all 4 connection holes, while the plastic spacers (Z7) between the TV rails (B,C) and the back of the TV. Choose the bolts that fit the TV's mounting holes diameter.

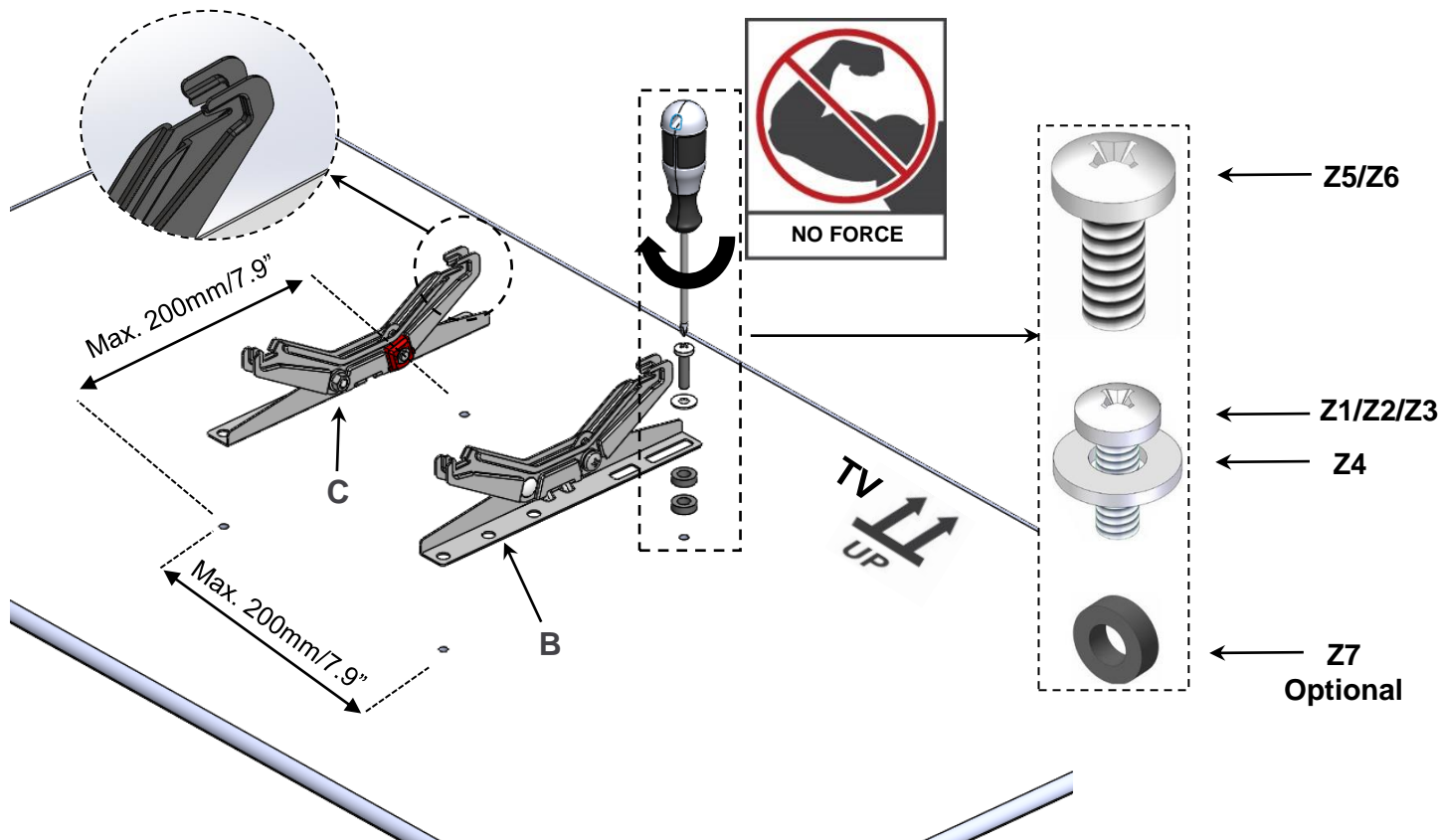

**2 Install the Wall plate on the Wall**

In order to set the desired height of the TV, measure the distance between the center of the TV's mounting holes and the bottom of the TV

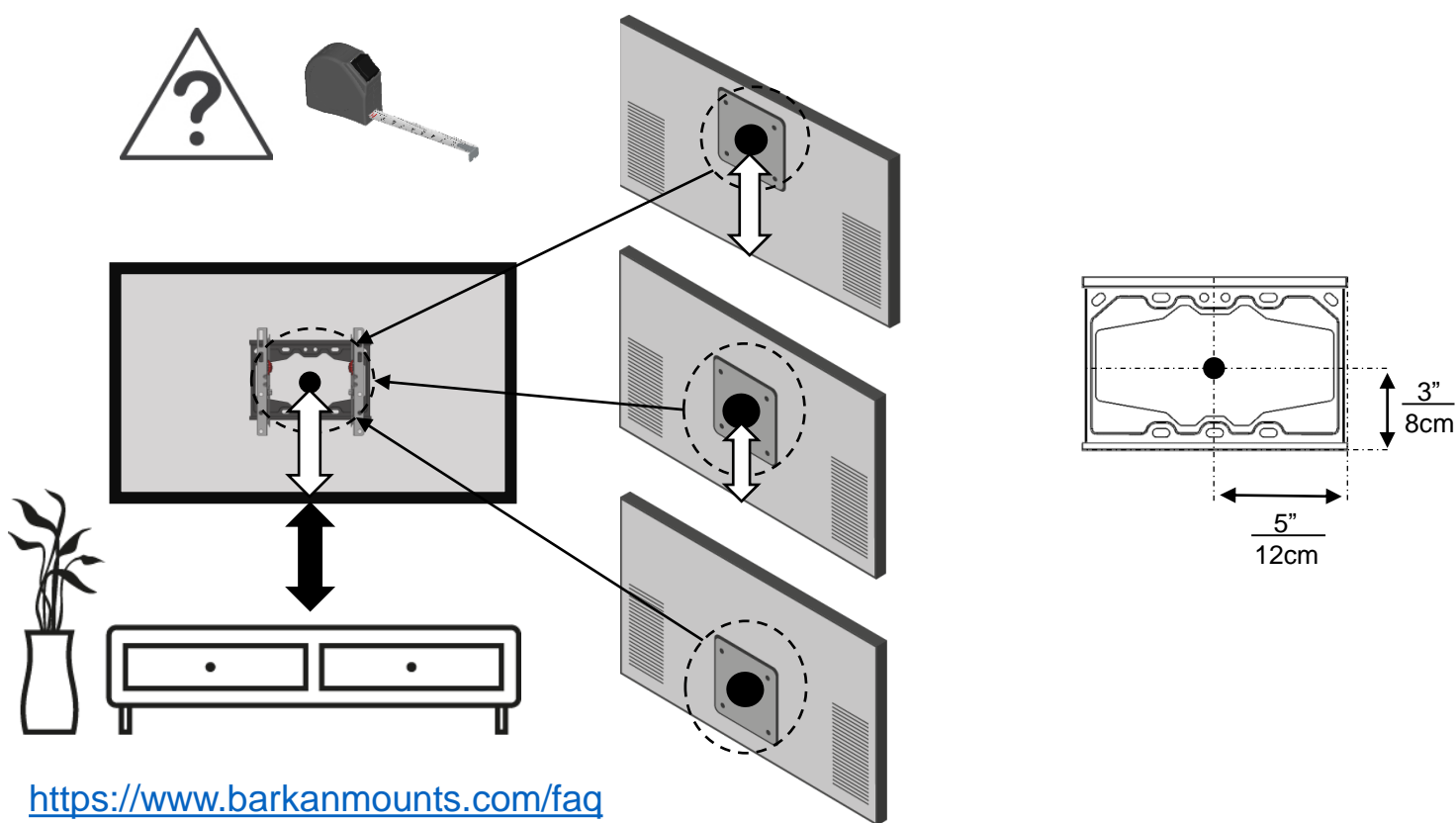

3

Follow the steps according to your wall type

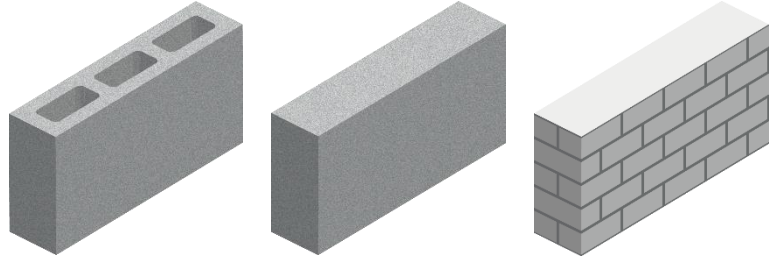

4

Mark the holes on the wall according to the required height

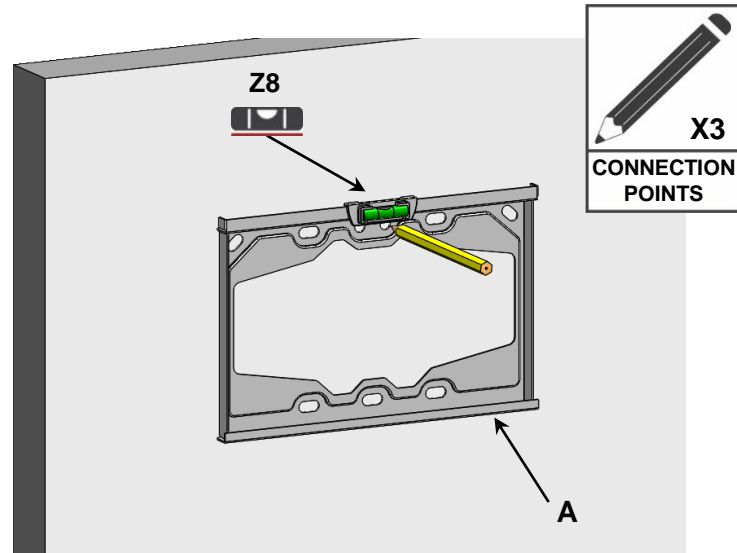
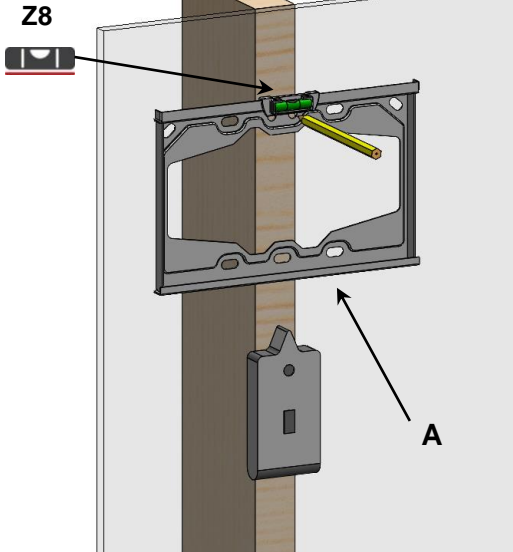

Use a Stud Finder

Make sure to mark all 3 of the drilling points

Make sure to mark all 3 of the drilling points

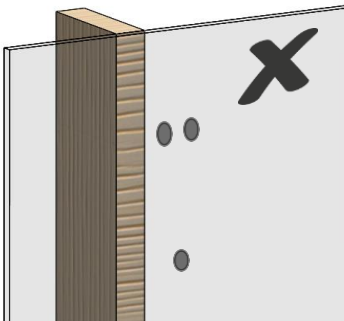
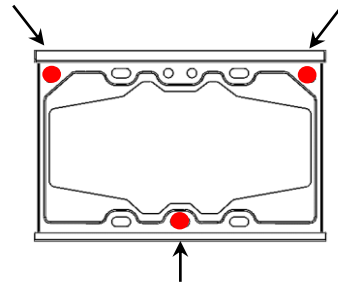
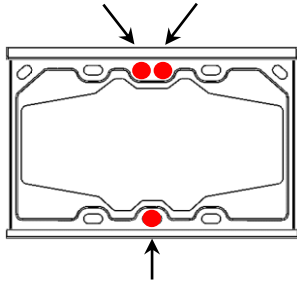

Make sure all holes are drilled inside the studs

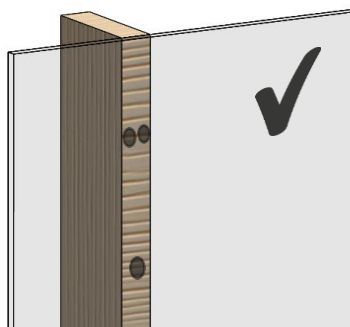

Make sure there are no electrical/water line in the wall before drilling and then drill according to the marking

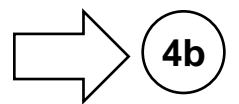
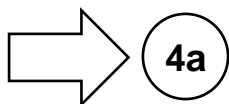

4a

Drill with 5/32" \ 4mm drill bit

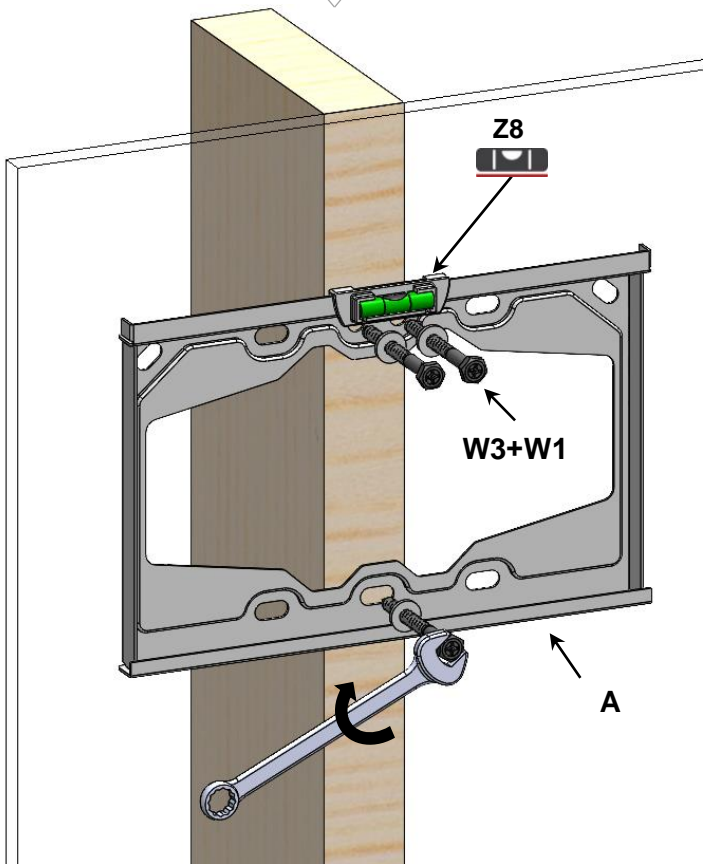
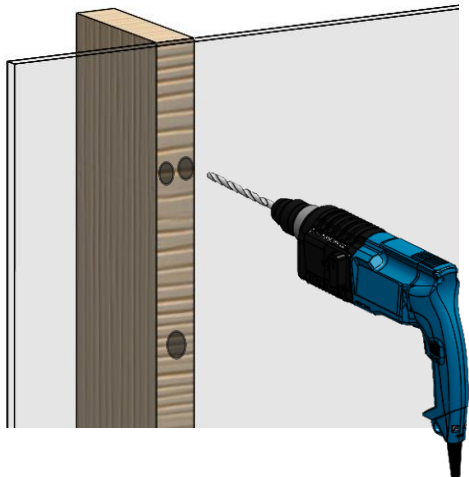
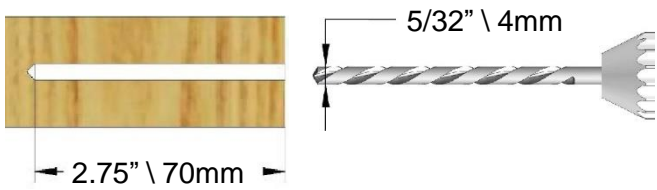

7/16" \ 11mm



4b

First use 1/4" \ 6mm drill bit

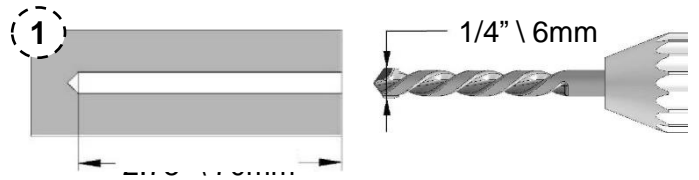

Afterwards use 3/8" \ 10mm drill bit

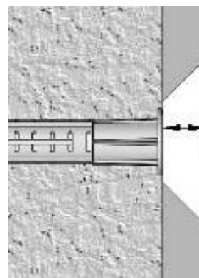
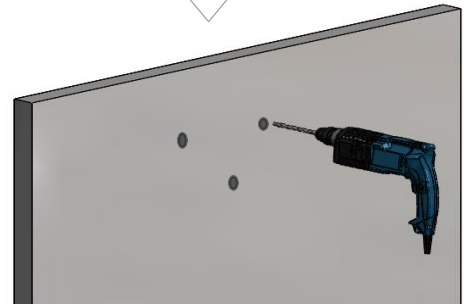
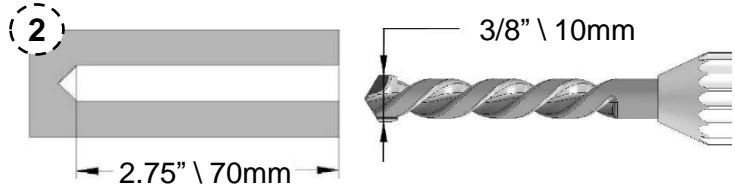

The anchor must be sunk at least 3/8"/10 mm into the plaster coating

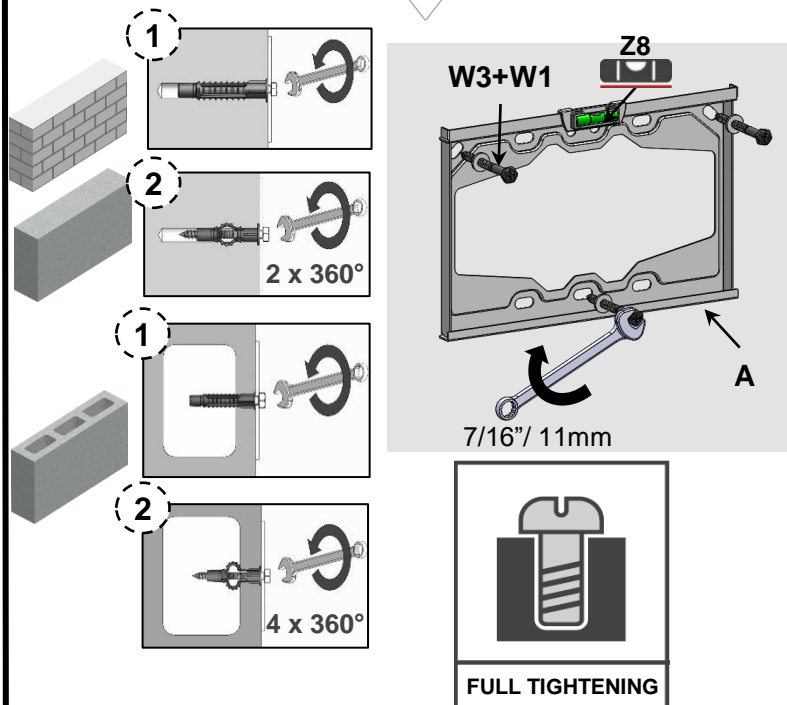
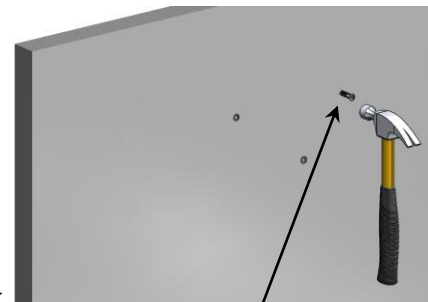

**5** Weight test

Apply force on the upper part of the Wall plate and make sure it is well connected

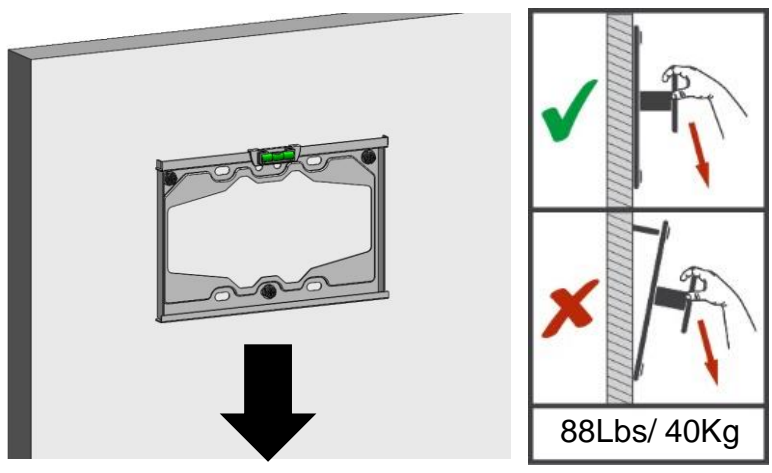

**6** Connect the TV to the wall plate by hooking the upper part of the vertical rails on the wall plate

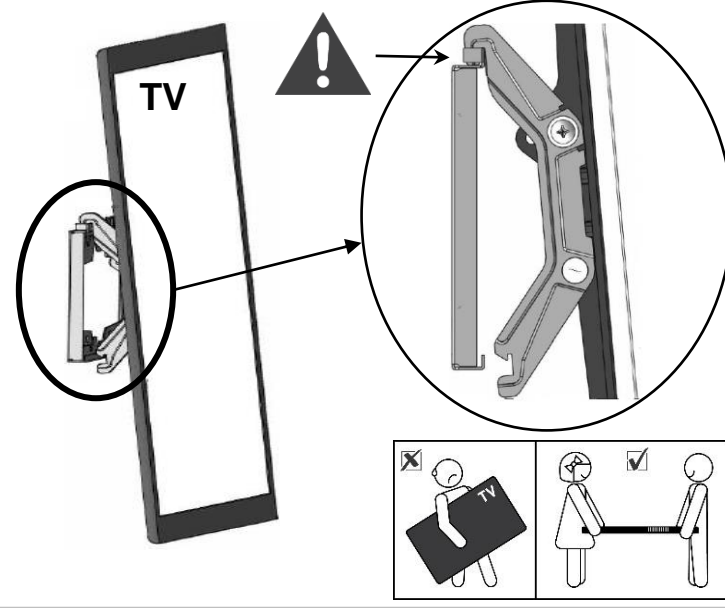

**7** Push slightly until you hear a "click".

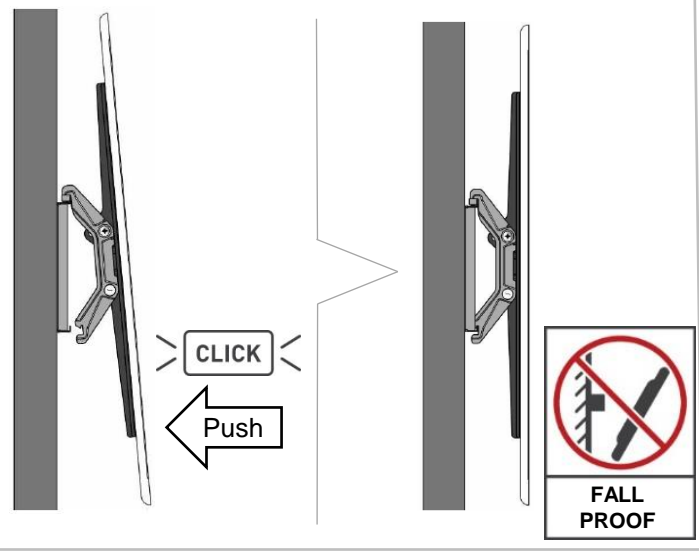

**8** Test if the auto-lock mechanism is functioning.

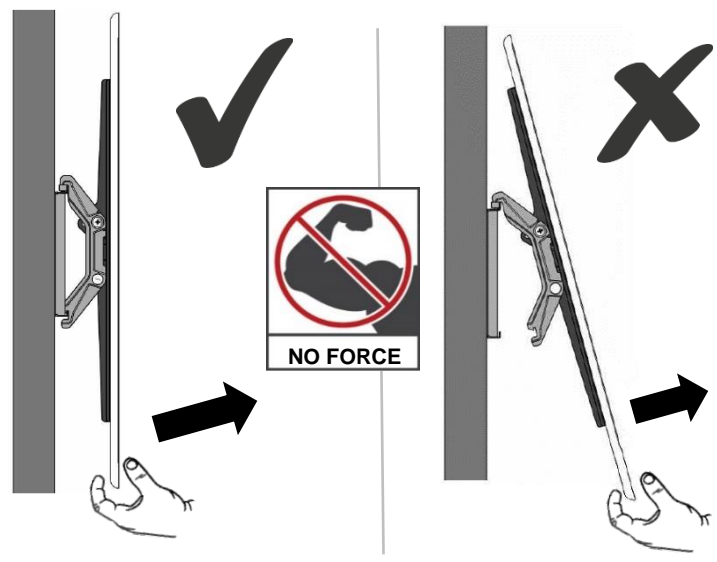

**9** To adjust the lateral position, first lift the screen and then move it to the required position.

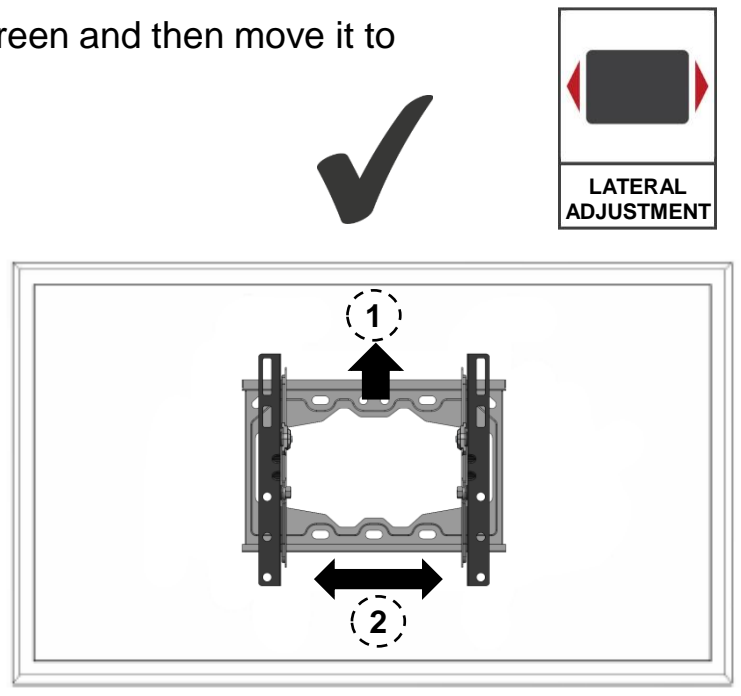
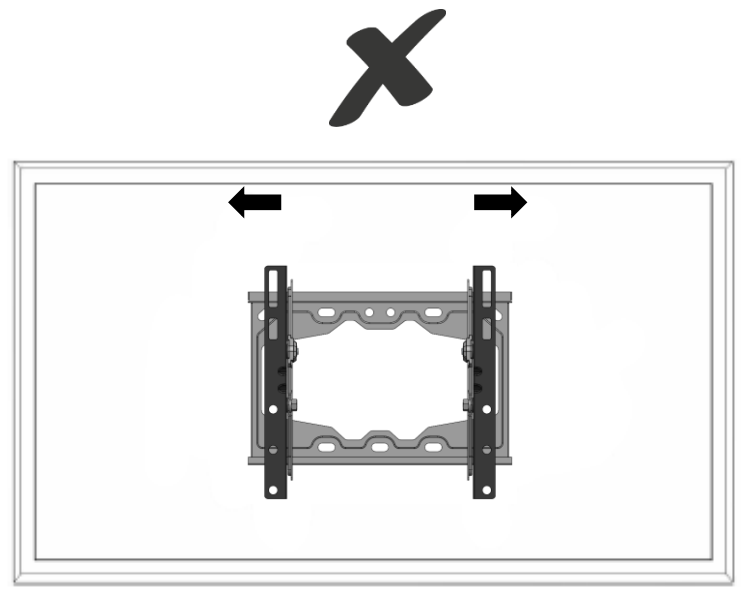

10

Tighten the screw in order to create the necessary friction for the tool free tilt mechanism.

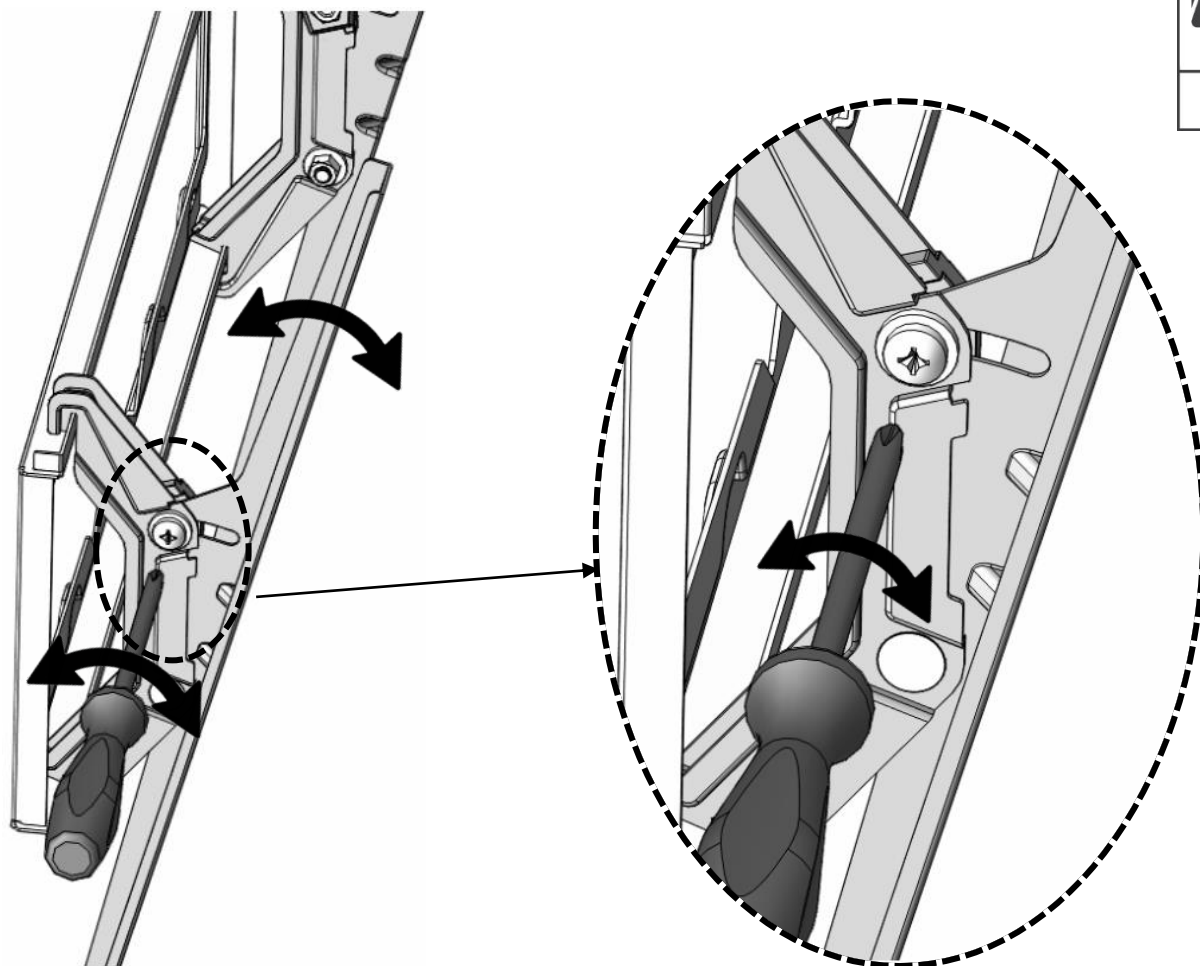

11

To disconnect the TV, lift it up gently and pull it out.

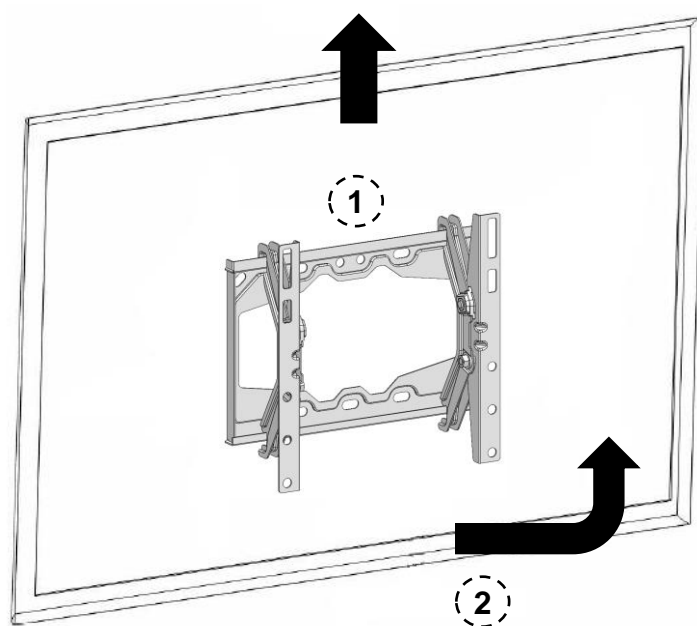

DISCONNECT

## BACKSCREEN CONNECTION POSITIONING OPTIONS

A few sizes of vertical rails (marked in blue) for TV backscreen connections are available. The positions are (Width x Height) 75x75 - 600x400 millimeters.

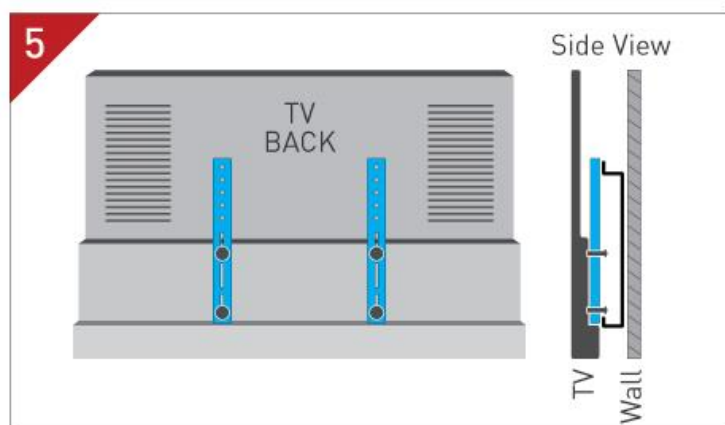
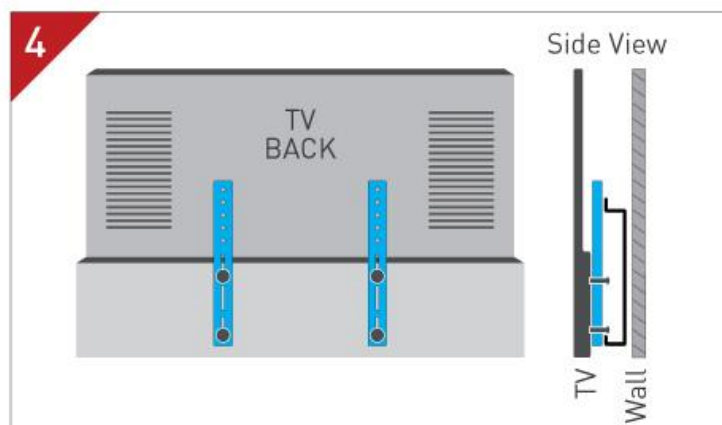
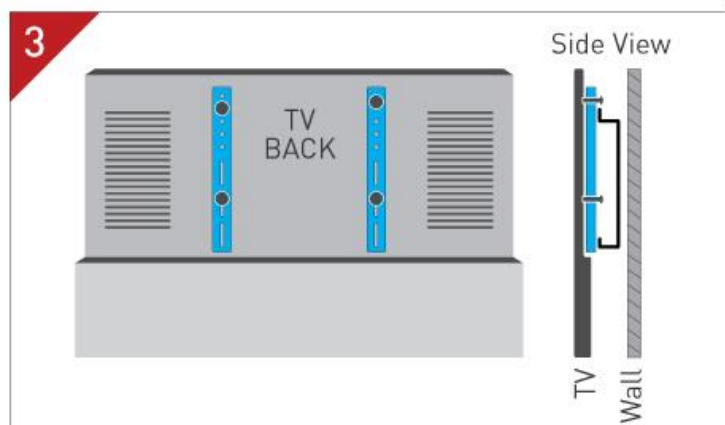
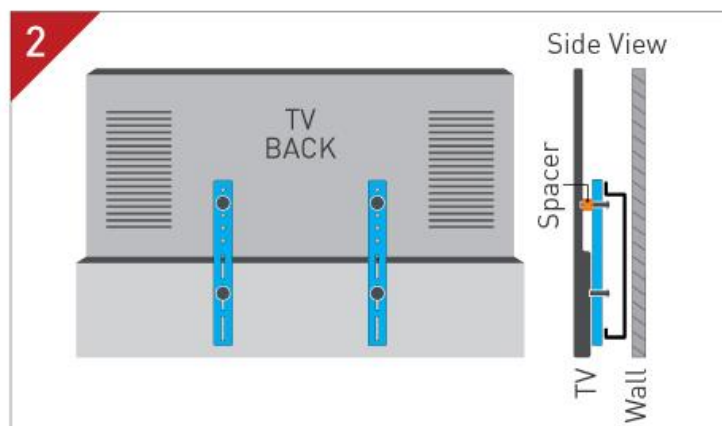
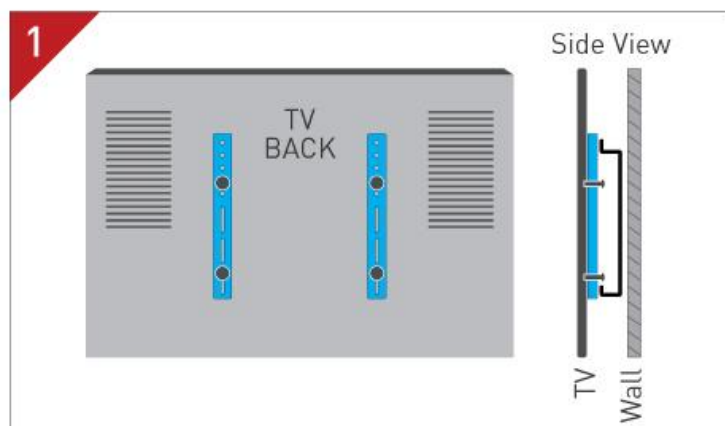

If your backscreen connections are not included in any of the positions, please contact us

[www.barkanmounts.com/support](http://www.barkanmounts.com/support)